

# Installation Note

---

**Noise Figure Measurement Capability to 26.5 GHz Upgrade Kit  
To Upgrade PNA N5244A and N5245A Options 400/419/423 or  
400/419/423/H85 to include Option H29**

**Upgrade Kit Order Number: N5244AU- H29 and N5245AU- H29**



**Agilent Technologies**

**Agilent Kit Number: N5245-60109**

**Agilent Document Number: N5245-90109**

**Printed in Malaysia February 15, 2012**

Supersedes: October 28, 2011

© Agilent Technologies, Inc. 2011-2012

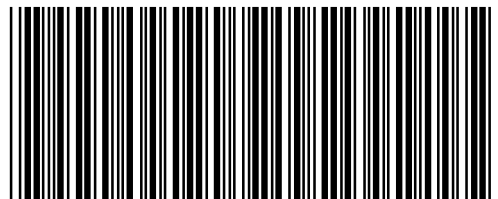

N5245-90109

---

## WARRANTY STATEMENT

THE MATERIAL CONTAINED IN THIS DOCUMENT IS PROVIDED "AS IS," AND IS SUBJECT TO BEING CHANGED, WITHOUT NOTICE, IN FUTURE EDITIONS. FURTHER, TO THE MAXIMUM EXTENT PERMITTED BY APPLICABLE LAW, AGILENT DISCLAIMS ALL WARRANTIES, EITHER EXPRESS OR IMPLIED WITH REGARD TO THIS MANUAL AND ANY INFORMATION CONTAINED HEREIN, INCLUDING BUT NOT LIMITED TO THE IMPLIED WARRANTIES OF MERCHANTABILITY AND FITNESS FOR A PARTICULAR PURPOSE. AGILENT SHALL NOT BE LIABLE FOR ERRORS OR FOR INCIDENTAL OR CONSEQUENTIAL DAMAGES IN CONNECTION WITH THE FURNISHING, USE, OR PERFORMANCE OF THIS DOCUMENT OR ANY INFORMATION CONTAINED HEREIN. SHOULD AGILENT AND THE USER HAVE A SEPARATE WRITTEN AGREEMENT WITH WARRANTY TERMS COVERING THE MATERIAL IN THIS DOCUMENT THAT CONFLICT WITH THESE TERMS, THE WARRANTY TERMS IN THE SEPARATE AGREEMENT WILL CONTROL.

---

## DFARS/Restricted Rights Notice

If software is for use in the performance of a U.S. Government prime contract or subcontract, Software is delivered and licensed as "Commercial computer software" as defined in DFAR 252.227-7014 (June 1995), or as a "commercial item" as defined in FAR 2.101(a) or as "Restricted computer software" as defined in FAR 52.227-19 (June 1987) or any equivalent agency regulation or contract clause. Use, duplication or disclosure of Software is subject to Agilent Technologies' standard commercial license terms, and non-DOD Departments and Agencies of the U.S. Government will receive no greater than Restricted Rights as defined in FAR 52.227-19(c)(1-2) (June 1987). U.S. Government users will receive no greater than Limited Rights as defined in FAR 52.227-14 (June 1987) or DFAR 252.227-7015 (b)(2) (November 1995), as applicable in any technical data.

---

## Safety Notes

The following safety notes are used throughout this document. Familiarize yourself with each of these notes and its meaning before performing any of the procedures in this document.

---

**WARNING**      **Warning denotes a hazard. It calls attention to a procedure which, if not correctly performed or adhered to, could result in injury or loss of life. Do not proceed beyond a warning note until the indicated conditions are fully understood and met.**

---

**CAUTION**      Caution denotes a hazard. It calls attention to a procedure that, if not correctly performed or adhered to, could result in damage to or destruction of the instrument. Do not proceed beyond a caution sign until the indicated conditions are fully understood and met.

---

---

## Description of the Upgrade

This upgrade adds noise figure measurement capability to 26.5 GHz for your Option 400/419/423 4-port analyzer or 400/419/423/H85 4-port analyzer by adding Option H29 which includes:

- a noise downconverter assembly
- a noise receiver board assembly
- two noise bypass switches
- cables

---

## Getting Assistance from Agilent

By internet, phone, or fax, get assistance with all your test and measurement needs.

### Contacting Agilent

Assistance with test and measurements needs and information on finding a local Agilent office are available on the Web at:

<http://www.agilent.com/find/assist>

If you do not have access to the Internet, please contact your Agilent field engineer.

---

**NOTE** In any correspondence or telephone conversation, refer to the Agilent product by its model number and full serial number. With this information, the Agilent representative can determine whether your product is still within its warranty period.

---

### If You Have Problems With the Upgrade Kit Contents

Agilent stands behind the quality of the upgrade kit contents. If you have problems with any item in the kit, email Agilent Component Test Division (CTD) Support at [support\\_ctd-soco@agilent.com](mailto:support_ctd-soco@agilent.com), or telephone the CTD Hotline at (707) 577-6802 and leave a voice mail message. Please include details of the problem.

---

## Getting Prepared

---

**CAUTION** The PNA contains extremely sensitive components that can be ruined if mishandled. Follow instructions carefully when making cable connections, especially wire harness connections.

The person performing the work accepts responsibility for the full cost of the repair or replacement of damaged components.

---

To successfully install this upgrade kit, you will need the following:

- A license key - refer to [“License Key Redemption” on page 5](#).
- A PDF copy or a paper copy of the PNA Service Guide - refer to [“Downloading the Online PNA Service Guide” on page 5](#).
- An ESD-safe work area - refer to [“Protecting Your Workspace from Electrostatic Discharge” on page 5](#).
- Correct tools - refer to [“Tools Required for the Installation” on page 6](#).
- Enough time - refer to [“About Installing the Upgrade” on page 6](#).
- Test equipment for the post-upgrade adjustments and full instrument calibration. To view the equipment list, click the Chapter 3 PDF bookmark [“Tests and Adjustments”](#) in the online Service Guide<sup>1</sup>.

### Verify the Options Installed in the PNA and Discard Kit Contents That Are Not Required

- If you already know which options are installed in the PNA, skip to the next bullet. If you don't know which options are installed in the PNA, power it up, select **Help > About Network Analyzer**, and note in the dialog box which options are installed.
- In [Table 1 on page 7](#), refer to the section “Cables and Overlay.” As per the table, discard the cables and overlay that are not required for the options installed in the PNA.

---

1. See [“Downloading the Online PNA Service Guide” on page 5](#).

## License Key Redemption

---

**NOTE** The enclosed Option Entitlement Certificate is a receipt, verifying that you have purchased a licensed option for the PNA of your choice. You must now use an Agilent Web page to request a license key for the instrument that will receive the option.

---

To enable the option product, you must request a license key from: <http://www.agilent.com/find/softwarelicense>. To complete the request, you will need to gather the following information:

- From the certificate
  - Order number
  - Certificate number
- From your instrument
  - Model number
  - Serial number
  - Host ID

The instrument information is available on the network analyzer – on the analyzer’s **Help** menu, click **About Network Analyzer**.

If you provide an email address, Agilent will promptly email your license key. Otherwise, you will receive your license key via postal mail.

### Downloading the Online PNA Service Guide

To view the online Service Guide for your PNA model number, use the following steps:

1. Go to [www.agilent.com](http://www.agilent.com)
2. In the Search box, enter the model number of the analyzer (Ex: N5245A) and click **Search**.
3. Click [Technical Support > Manuals](#).
4. Click [Service Manual](#).
5. Click the service guide title to load the PDF file.
6. When the PDF of the Service Guide is displayed, scroll through the Contents section bookmarks to locate the information needed.

### Protecting Your Workspace from Electrostatic Discharge

For information, click on the Chapter 1 PDF bookmark, “[Electrostatic Discharge Protection](#)” in the online Service Guide<sup>1</sup>.

---

1. See “[Downloading the Online PNA Service Guide](#)” on page 5.

## ESD Equipment Required for the Installation

Description	Agilent Part Number
ESD grounding wrist strap	9300-1367
5-ft grounding cord for wrist strap	9300-0980
2 x 4 ft conductive table mat and 15-ft grounding wire	9300-0797
ESD heel strap (for use with conductive floors)	9300-1308

## Tools Required for the Installation

Description	Qty	Part Number
T-8 TORX driver - set to 6 in-lbs (0.68 N.m)	1	N/A
T-10 TORX driver - set to 9 in-lbs (1.02 N.m)	1	N/A
T-20 TORX driver - set to 21 in-lbs (2.38 N.m)	1	N/A
5/16-in (8 mm) nutsetter or open end torque wrench - set to 10 in-lbs (1.13 N.m)	1	N/A

**CAUTION** Use a 5/16-in torque wrench set to 10 in-lbs on all cable connections except the front panel and some rear panel bulkhead connectors. Torque these connections to 21 in-lb.

## About Installing the Upgrade

Products affected . . . . .	N5244A/45A 4-port Network Analyzer Options 400/419/423 or Options 400/419/423/H85
Installation to be performed by . . . . .	Agilent service center or personnel qualified by Agilent
Estimated installation time . . . . .	5.0 hours
Estimated adjustment time . . . . .	0.5 hours
Estimated full instrument calibration time . . . . .	4.5 hours

## Items Included in the Upgrade Kit<sup>1</sup>

Check the contents of your kit against the following list. If any part is missing or damaged, contact Agilent Technologies. Refer to [“Getting Assistance from Agilent”](#) on page 3.

**Table 1 Contents of Upgrade Kit N5245-60109**

Ref Desig.	Description	Qty	Part Number
-	Installation note (this document)	1	N5245-90109
-	H29 User’s Guide	1	N5245-90013
<b>Accessory Items</b>			
<p><b>Note to Installer</b>            These two items are used when performing vector-corrected noise figure measurements and are not used in the upgrade. They are packaged separately in the kit and must remain with the analyzer.</p>			
-	2.4 mm male-to-2.4 mm female adapter used to connect an ECal module	1	85056-60007
-	RF cable used to connect an ECal module	1	N5245-20140
<b>Assemblies</b>			
A9	Noise receiver board	1	N5242-60098
A56	Noise bypass switch, port 1	2	N1811-60009
A57	Noise bypass switch, port 2		
A58	Bridge	1	5087-7729
A59	Noise downconverter	1	5087-7767 Was 5087-7316
<b>Hardware/Miscellaneous</b>			
-	Bracket, port 1 switch	1	N5245-00026
-	Bracket, bridge/port 2 switch	1	N5245-00032
-	Washer, lock, helical, 3.1 mm-ID, 6.2 mm-OD	2	2190-0584
-	Machine screw, M3.0 x 14, pan head	3	0515-2994 Was 0515-0665
-	Machine screw, M2.5 x 20, pan head	4	0515-1992
-	Machine screw, M3.0 x 8, pan head	3	0515-0372
-	Machine screw, M2.5 x 8, flat head	2	0515-2487
W141	Adapter, straight 2.92 mm male-to-2.92 mm male, 50 ohm; A59 Noise Downconverter to A58 port 2 bridge	1	1250-3576
-	Inner cover (to replace existing inner cover)	1	N5247-00004
-	Mylar tape (applied to chassis in some older analyzers)	1	0460-0042

1. In addition to the upgrade kit, the shipment includes an Option Entitlement Certificate. Refer to [“License Key Redemption”](#) on page 5 for important information about this certificate.

**Table 1 Contents of Upgrade Kit N5245-60109**

Ref Desig.	Description	Qty	Part Number
-	Cable tie	5	1400-0249
-	Dust cap for test port	4	1400-0214
<b>Cables and Overlay (listed in the order in which they are installed)</b>			
<b>Cables and Overlay for Options 400/419/423 Only</b> <i>Discard these three parts if you have Option H85 installed in the PNA.</i>			
W135	A56 port 1 noise bypass switch to A42 port 1 bias tee	1	N5245-20082
W137	A57 port 2 noise bypass switch to A45 port 2 bias tee	1	N5245-20105
-	Lower 4-port front panel overlay	1	N5242-80012
<b>Cables and Overlay for Options 400/419/423/H85 Only</b> <i>Discard these three parts if you do <u>not</u> have Option H85 installed in the PNA.</i>			
W125	A57 port 2 noise bypass switch to A36 test port 2 coupler	1	N5245-20138
W124	A56 port 1 noise bypass switch to A33 test port 1 coupler	1	N5245-20137
-	Lower 4-port front panel overlay	1	N5242-80019
<b>Cables for Both Options 400/419/423 and 400/419/423/H85</b>			
-	Ribbon cable: A59 noise downconverter to <b>A23</b> test set motherboard J550	1	N5245-60013
W152	A59 noise downconverter J4 to A9 noise receiver board J9	1	N5242-60041
W140	A57 port 2 noise bypass switch to A58 port 2 bridge arm	1	N5245-20107
W139	A57 port 2 noise bypass switch to A58 port 2 bridge thru	1	N5245-20079
W136	A57 port 2 noise bypass switch to front-panel Port 2 CPLR THRU	1	N5245-20080
W134	A56 port 1 noise bypass switch to front-panel port 1 CPLR THRU	1	N5245-20084
W133	A56 port 1 noise bypass switch to front-panel port 1 SOURCE OUT	1	N5245-20083
W132	A56 port 1 noise bypass switch to A38 port 1 source attenuator	1	N5245-20081
W154	A59 noise downconverter to A28 mixer brick	1	N5245-20132
W151	A59 noise downconverter LO Out to A9 noise receiver board LO In	1	N5245-20133
W153	A59 noise downconverter RF Out to A9 noise receiver board RF In	1	N5245-20134

---

**NOTE** Extra quantities of items such as protective plastic caps, screws, cable ties, and cable clamps may be included in this upgrade kit. It is normal for some of these items to remain unused after the upgrade is completed.

---



---

## Installation Procedure for the Upgrade

The network analyzer must be in proper working condition prior to installing this option. Any necessary repairs must be made before proceeding with this installation.

### Overview of the Installation Procedure

---

**WARNING**     **The next steps of this installation require the removal of the analyzer's protective outer covers. The analyzer must be powered down and disconnected from the mains supply before performing these steps.**

---

- Step 1. Obtain a Keyword.
- Step 2. Remove the Outer Cover.
- Step 3. Remove the Inner Cover.
- Step 4. Remove the Front Panel Assembly.
- Step 5. Locate the Corner of the Test Set Motherboard Shown in Figure 1.
- Step 6. Remove the A23 Test Set Motherboard.
- Step 7. Inspect Test Set Deck Chassis to Determine if Tape is Needed.
- Step 8. Remove Some Existing Cables.
- Step 9. Assemble the A58 Bridge and A59 Noise Down Converter.
- Step 10. Assemble the Noise Assembly onto the Bracket.
- Step 11. Install the Switch to the Noise Assembly.
- Step 12. Install the Noise Assembly to the Chassis.
- Step 13. Assemble the A56 Port 1 Noise Bypass Switch onto the Bracket.
- Step 14. Install the A56 Noise Bypass Switch.
- Step 15. Install the Test Set Cables.
- Step 16. Install the A9 Noise Receiver Board.
- Step 17. Replace the Lower Front Panel Overlay.
- Step 18. Reinstall the A24 IF Multiplexer Board.
- Step 19. Reinstall the A23 Test Set Motherboard.
- Step 20. Install the New Ribbon Cable on the A23 Test Set Motherboard.
- Step 21. Reroute the A44 and A45 Bias Tees Wire Harnesses.
- Step 22. Reinstall Front Panel Assembly.
- Step 23. Install the New Inner Cover.
- Step 24. Reinstall the Outer Cover.
- Step 25. Enable Option H29.
- Step 26. Perform Post-Upgrade Adjustments and Calibration.

[Step 27. Prepare the PNA for the User.](#)

**Step 1. Obtain a Keyword**

Follow the instructions on the keyword Entitlement Certificate supplied to obtain a keyword for installation of this upgrade.

Once the keyword has been obtained, you can proceed with the installation.

**Step 2. Remove the Outer Cover**

For instructions, click the Chapter 7 bookmark "Removing the Covers" in the PDF Service Guide<sup>1</sup>.

**Step 3. Remove the Inner Cover**

For instructions, click the Chapter 7 bookmark "Removing the Covers" in the PDF Service Guide<sup>1</sup>. This inner cover may be discarded since it will be replaced later.

**Step 4. Remove the Front Panel Assembly**

For instructions, click the Chapter 7 bookmark "Removing and Replacing the Front Panel Assembly" in the PDF Service Guide<sup>1</sup>.

---

1. See ["Downloading the Online PNA Service Guide"](#) on page 5.

**Step 5. Locate the Corner of the Test Set Motherboard Shown in Figure 1**

Locate the corner of the Test Set Motherboard shown in [Figure 1](#) - look for the two small black connectors labeled J554 and J101. Later, you will examine the test set deck chassis underneath this corner of the board.

**Figure 1 Corner of Test Set Motherboard to be Located**

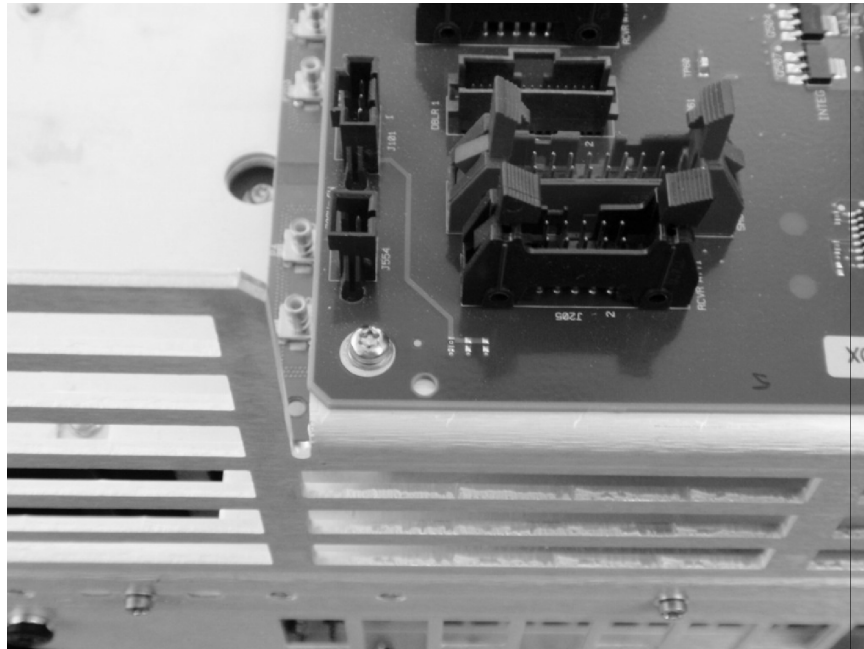

N5245\_109\_13

**Step 6. Remove the A23 Test Set Motherboard**

For instructions, click the Chapter 7 bookmark “Removing and Replacing the A23 test set motherboard” in the PDF Service Guide<sup>1</sup>.

## Step 7. Inspect Test Set Deck Chassis to Determine if Tape is Needed

Examine the test set deck chassis under the corner of the Test Set Motherboard you located earlier, and compare it to the photo in [Figure 2](#). If a cut-out notch exists on the chassis where the tape is shown in [Figure 2](#), you do NOT need to install the tape. However, if a cut-out notch does NOT exist, install a piece of mylar tape (included in the kit contents) as shown in the graphic. The tape eliminates any possibility of the Test Set Motherboard shorting against the test set deck.

**Figure 2** Test Set Deck Chassis with Mylar Tape Installed

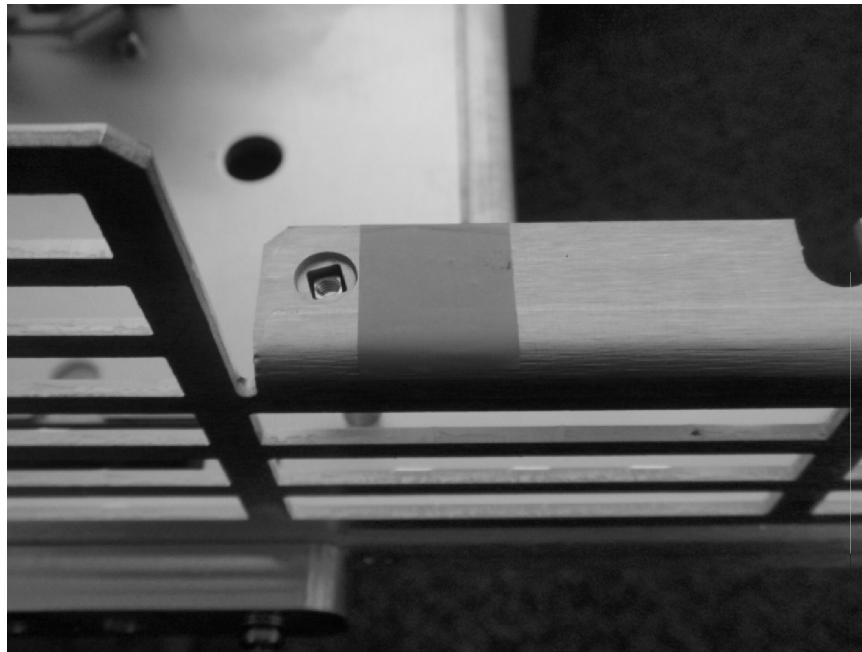

N5245\_109\_14

## Step 8. Remove Some Existing Cables

---

**CAUTION** Be careful not to damage the center pins of the semirigid cables. Some flexing of the cables may be necessary but do not over-bend them.

---

1. Place the analyzer bottom-side up on a flat surface.
2. Remove the following cables in the order listed. These two cables may be discarded - they will not be reinstalled.  
To see an image showing the location of these cables, click either the Chapter 6 bookmark “4-Port Configuration, Options 400/419/423” or “4-Port Configuration, Options 400/419/423/H85” in the PDF Service Guide<sup>1</sup>.
  - W82 (N5245-20077) A38 port 1 source attenuator to front-panel Port 1 SOURCE OUT
  - W58 (N5245-20095) A28 mixer brick to 50 ohm load

**Option 400/419/423 only:**

1. Remove the following cables in the order listed. These three cables may be discarded - they will not be reinstalled.

To see an image showing the location of these cables, click the Chapter 6 bookmark "4-Port Configuration, Options 400/419/423" in the PDF Service Guide<sup>1</sup>.

- W96 (N5245-20087) A45 port 2 bias tee to front-panel Port 2 CPLR THRU
- W84 (N5245-20085) A42 port 1 bias tee to front-panel Port 1 CPLR THRU

**Option 400/419/423/H85 only:**

1. Remove the following cables in the order listed. These two cables may be discarded - they will not be reinstalled.

To see an image showing the location of these cables, click the Chapter 6 bookmark "4-Port Configuration, Options 400/419/423/H85" in the PDF Service Guide<sup>1</sup>.

- W20 (N5245-20099) Front panel port 1 CPLR THRU to A33 port 1 coupler
- W32 (N5245-20097) Front panel port 2 CPLR THRU to A36 port 2 coupler

## Step 9. Assemble the A58 Bridge and A59 Noise Down Converter

Follow the five instructions shown in [Figure 3](#) for this step of the procedure. New parts are listed in [Table 1](#) on [page 7](#) of this document.

**Figure 3** A58 Bridge and A59 Noise Down Converter

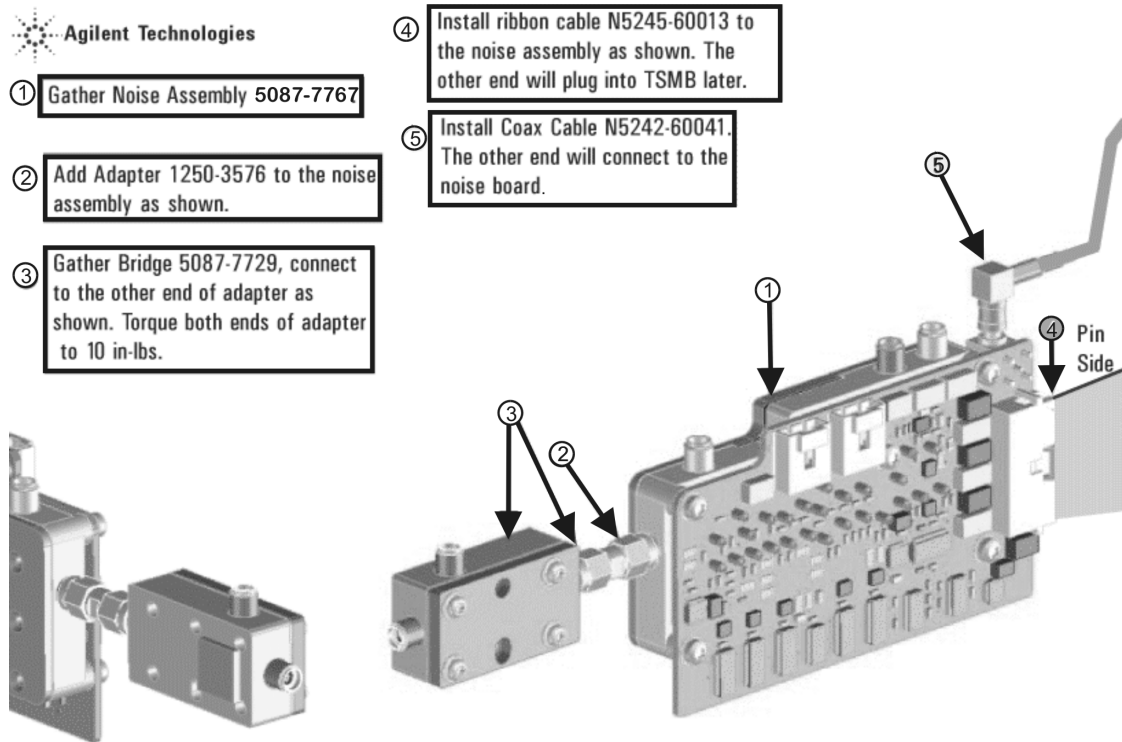

N5245\_109\_03

## Step 10. Assemble the Noise Assembly onto the Bracket

Follow the two instructions shown in [Figure 4](#) for this step of the procedure. New parts are listed in [Table 1](#) on [page 7](#) of this document.

**Figure 4**                      **Bracket to Noise Assembly Positioning**

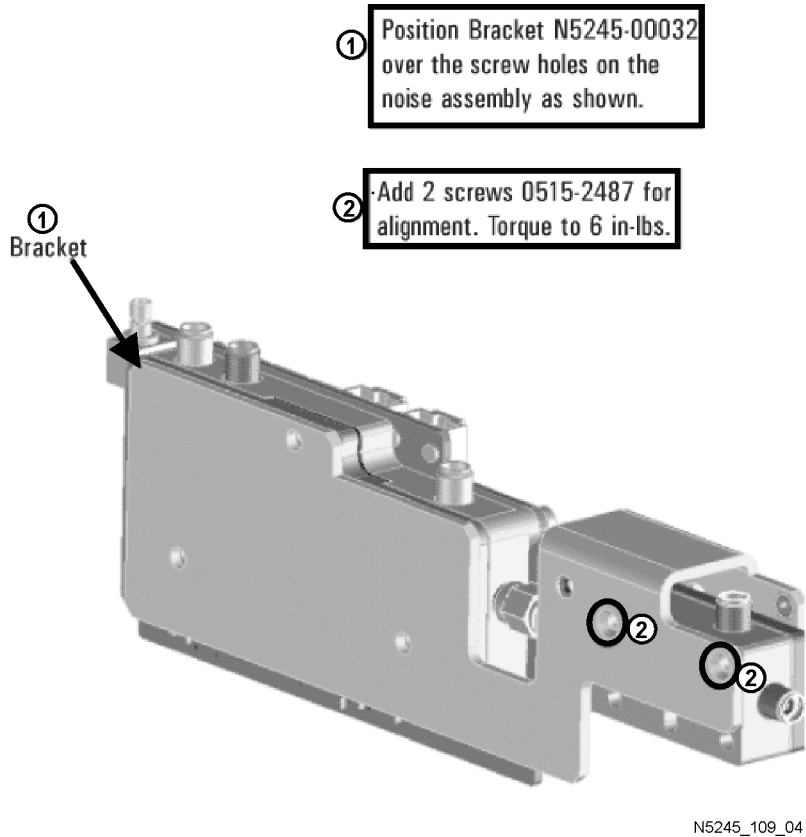

## Step 11. Install the Switch to the Noise Assembly

Follow the three instructions shown in [Figure 5](#) for this step of the procedure. New parts are listed in [Table 1](#) on [page 7](#) of this document.

**Figure 5**                    **A57 Switch Installation**

① Install Switch N1811-60009 to bracket N5245-00032 as shown. Secure with washer 2190-0584 X2 and screws 0515-1992 X2. Torque to 9 in-lbs.

② Plug switch harness to down converter J11.

③ Gather extra harness and tie down with 1400-0249 cable tie.

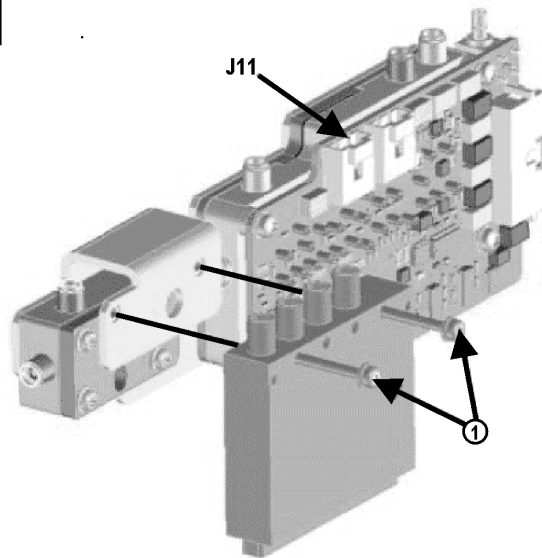

N5245\_109\_06



## Step 12. Install the Noise Assembly to the Chassis

Follow the two instructions shown in [Figure 6](#) for this step of the procedure. New parts are listed in [Table 1](#) on [page 7](#) of this document.

**Figure 6 Noise Assembly to Chassis Installation**

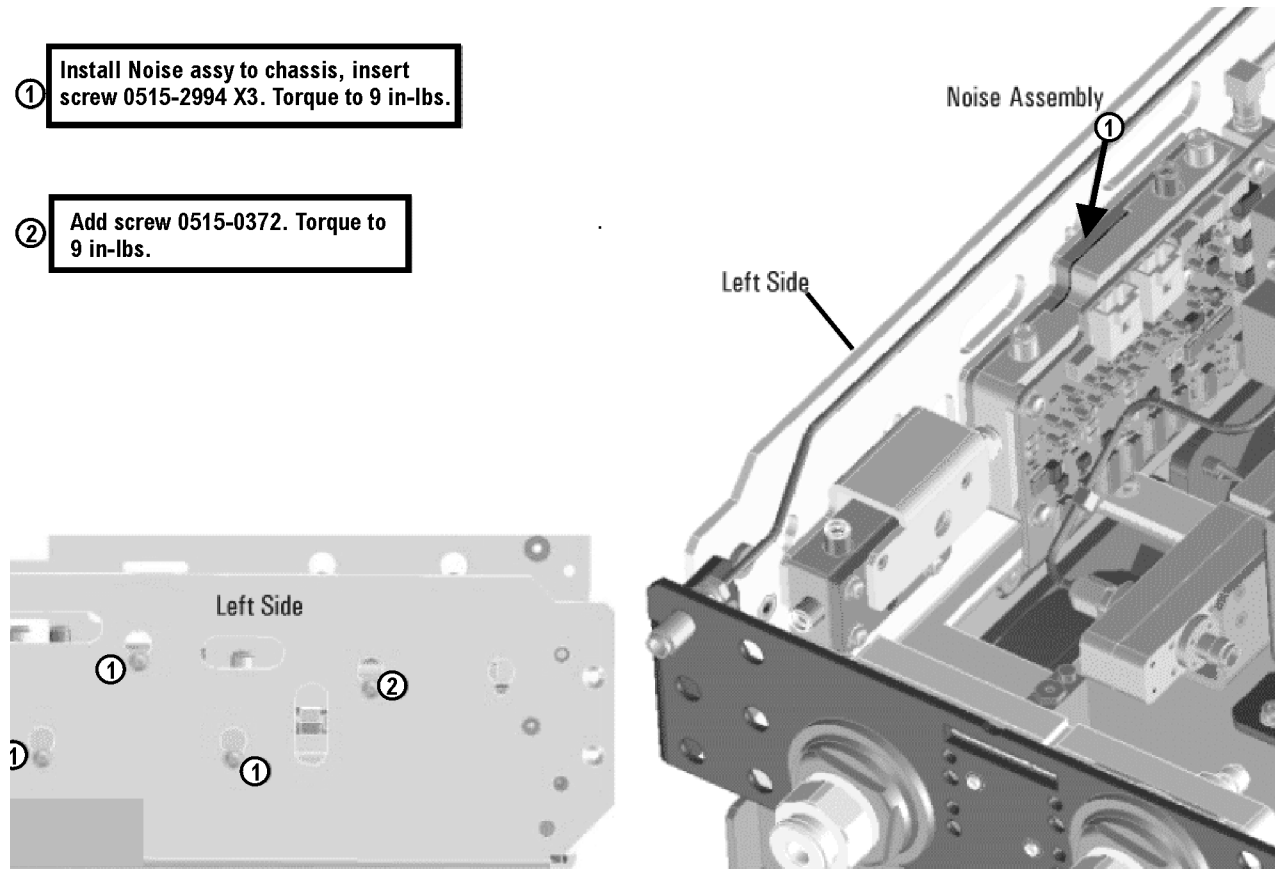

N5245\_109\_05

### Step 13. Assemble the A56 Port 1 Noise Bypass Switch onto the Bracket

Follow the instruction shown in [Figure 7](#) for this step of the procedure. New parts are listed in [Table 1 on page 7](#) of this document.

**Figure 7**                      **A56 Port 1 Noise Bypass Switch Assembly**

① Install Switch N1811-60009 to bracket N5245-00026 as shown. Secure with screws 0515-1992 X2. Torque to 6 in-lbs.

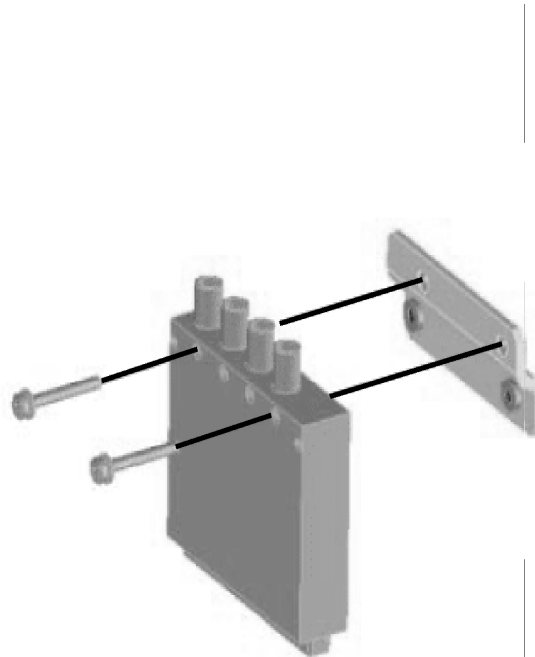

N5245 109 01

## Step 14. Install the A56 Noise Bypass Switch

Follow the two instructions shown in [Figure 8](#) for this step of the procedure. New parts are listed in [Table 1](#) on [page 7](#) of this document.

**Figure 8** A56 Port 1 Noise Bypass Switch Installation

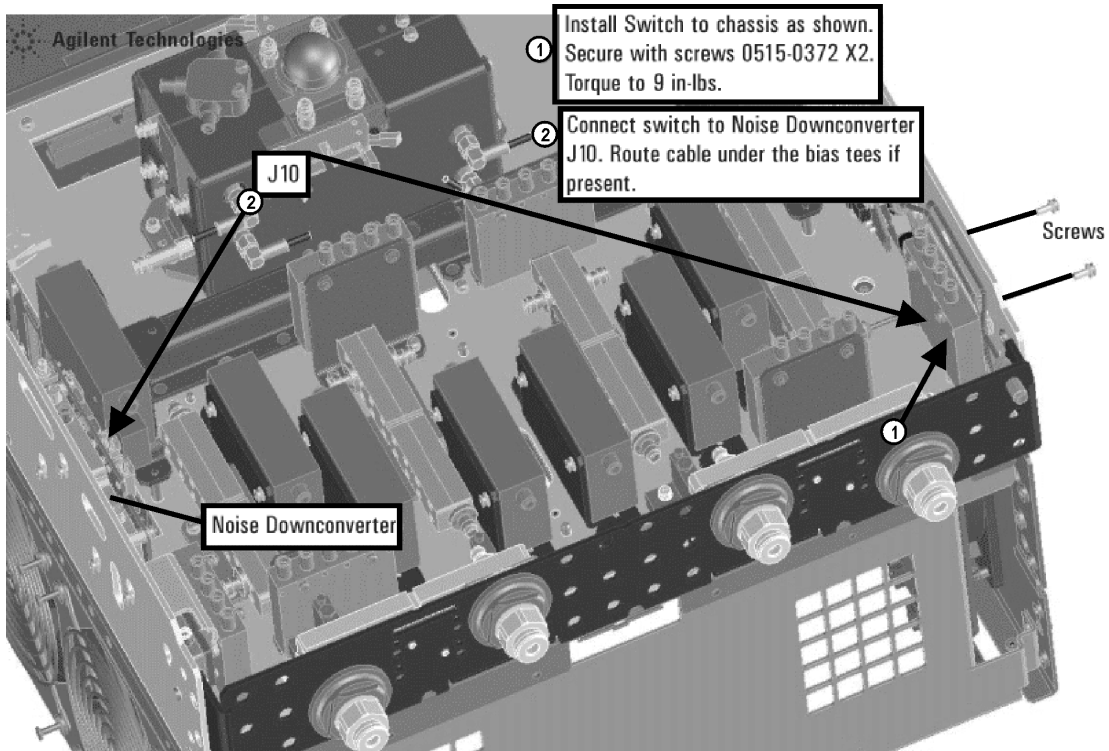

N5245\_109\_02

## Step 15. Install the Test Set Cables

---

**CAUTION** Follow instructions carefully when making cable connections, especially wire harness connections. Incorrect connections can destroy components, resulting in additional customer costs.

---

**CAUTION** Use a 5/16-in torque wrench set to 10 in-lbs on all cable connections except the front and rear panel bulkhead connectors. Torque these connections to 21 in-lb.

---

### PNA Options 400/419/423 Only

Install the following cables in the order listed. To see images showing the location of these cables, refer to [Figure 9](#) and [Figure 10](#). New parts are listed in [Table 1 on page 7](#).

- W135 (N5245-20082) A56 port 1 noise bypass switch to A42 port 1 bias tee
- W137 (N5245-20105) A57 port 2 noise bypass switch to A45 port 2 bias tee

**Figure 9** Option 400/419/423 Only: N5245-20082 Cable Installation

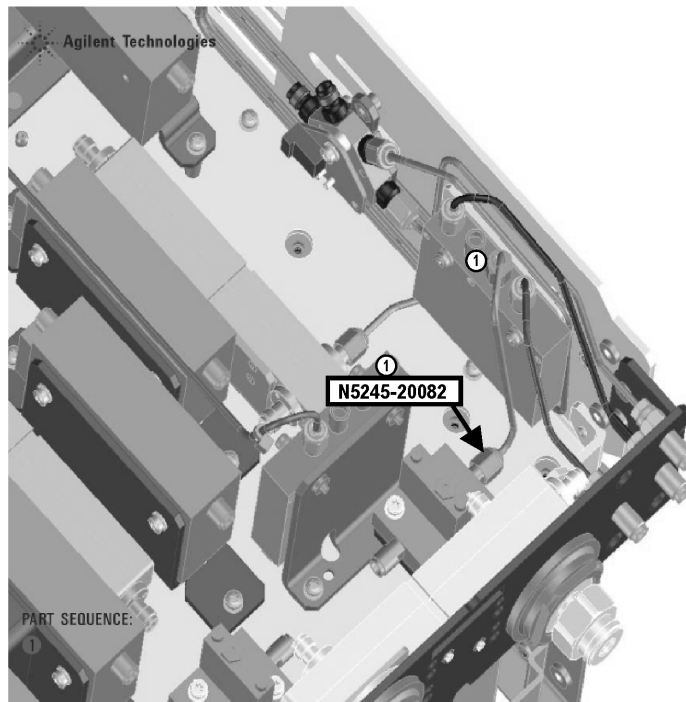

N5245\_109\_12

**Figure 10**

**Option 400/419/423 Only: N5245-20105 Cable Installation**

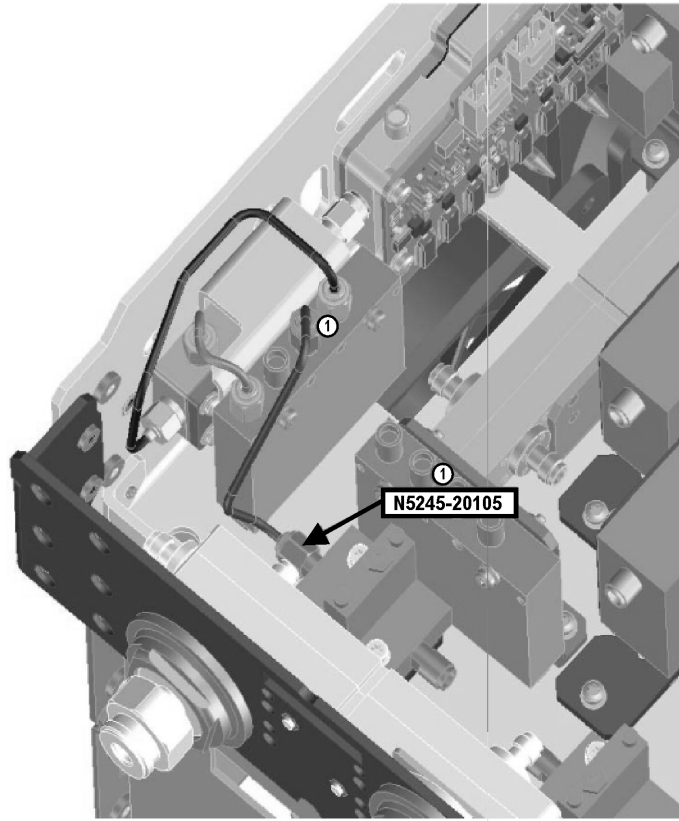

N5245\_109\_11

### PNA Options 400/419/423/H85 Only

Install the following cables in the order listed. To see images showing the location of these cables, refer to [Figure 11](#) and [Figure 12](#). New parts are listed in [Table 1 on page 7](#).

- W124 (N5245-20137) A56 port 1 noise bypass switch to A33 test port 1 coupler
- W125 (N5245-20138) A57 port 2 noise bypass switch to A36 test port 2 coupler

**Figure 11**                      **Option 400/419/423/H85 Only: N5245-20137 Cable Installation**

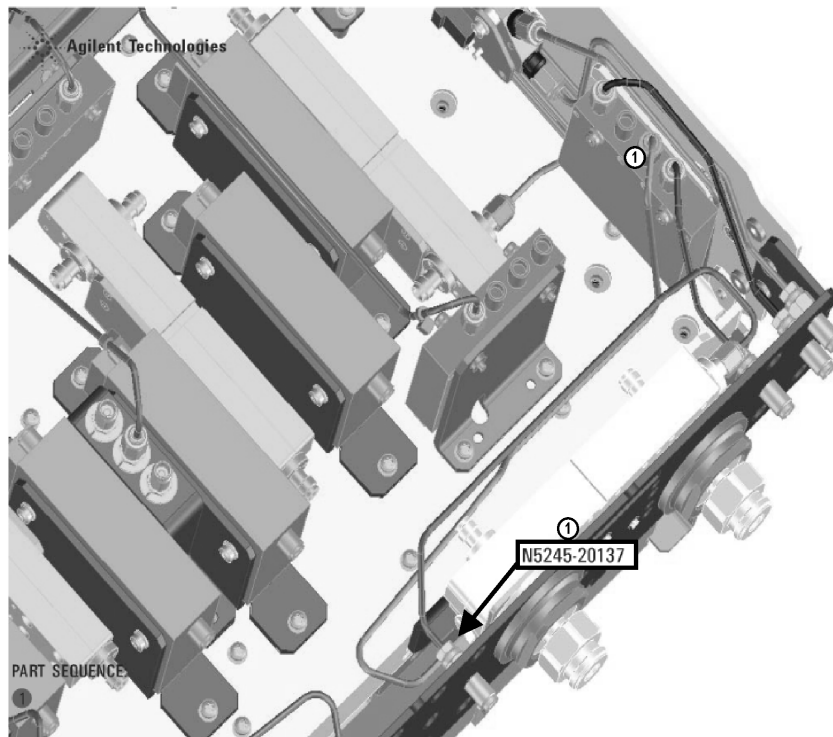

N5245\_109\_09

**Figure 12**

**Option 400/419/423/H85 Only: N5245-20138 Cable Installation**

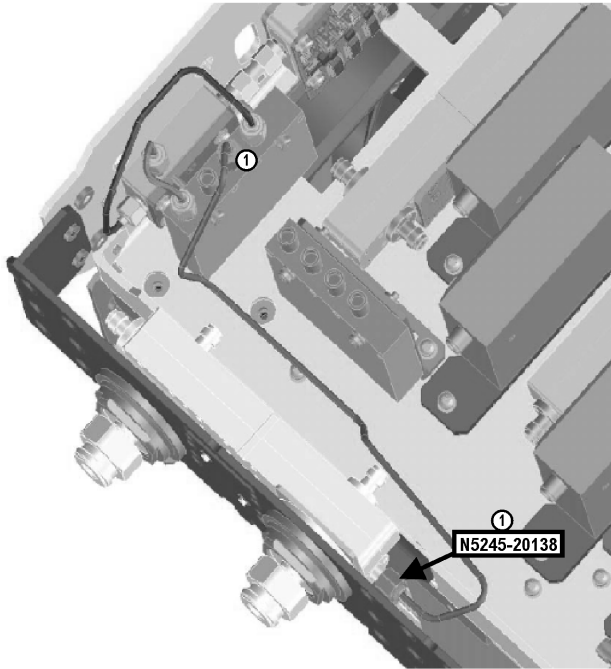

N5245\_109\_08

**PNA Options 400/419/423 and 400/419/423/H85**

Install the following cables in the order listed. To see images showing the location of these cables, refer to [Figure 13](#). New parts are listed in [Table 1 on page 7](#).

- W140 (N5245-20107) A57 port 2 noise bypass switch to A58 port 2 bridge arm
- W139 (N5245-20079) A57 port 2 noise bypass switch to A58 port 2 bridge thru
- W136 (N5245-20080) A57 port 2 noise bypass switch to front-panel Port 2 CPLR THRU
- W134 (N5245-20084) A56 port 1 noise bypass switch to front-panel port 1 CPLR THRU
- W133 (N5245-20083) A56 port 1 noise bypass switch to front-panel port 1 SOURCE OUT
- W132 (N5245-20081) A56 port 1 noise bypass switch to A38 port 1 source attenuator
- W154 (N5245-20132) A59 noise downconverter to A28 mixer brick
- W153 (N5245-20134) A59 noise downconverter RF Out to A9 noise receiver board RF In (One end of this cable will connect later to the A9 noise receiver board.)
- W151 (N5245-20133) A59 noise downconverter LO Out to A9 noise receiver board LO In (One end of this cable will connect later to the A9 noise receiver board.)

Figure 13

Options 400/419/423/H29 and Options 400/419/423/H29/H85 Cable Installation

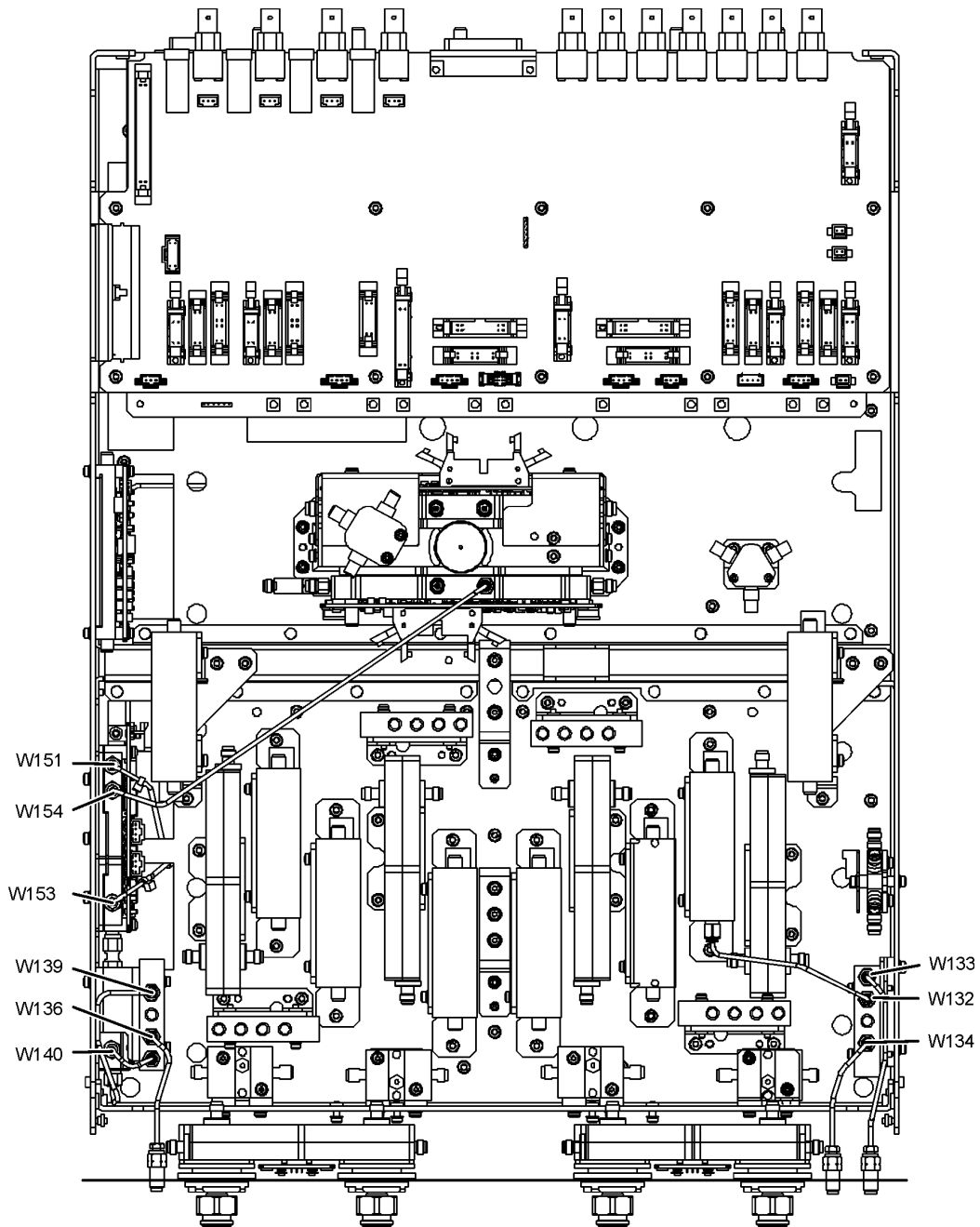

(Although this graphic shows some components that are not included with Option H85, the locations of the labeled cables are accurate for Option H85.)

N5245\_109\_10



## Step 16. Install the A9 Noise Receiver Board

1. Place the analyzer top-side up on a flat surface.
2. Follow the four instructions shown in [Figure 14](#) for this step of the procedure. Make sure the A9 noise receiver board is fully seated in the motherboard connector. New parts are listed in [Table 1 on page 7](#) of this document.

**Figure 14** A9 Noise Receiver Board (and Cables) Installation

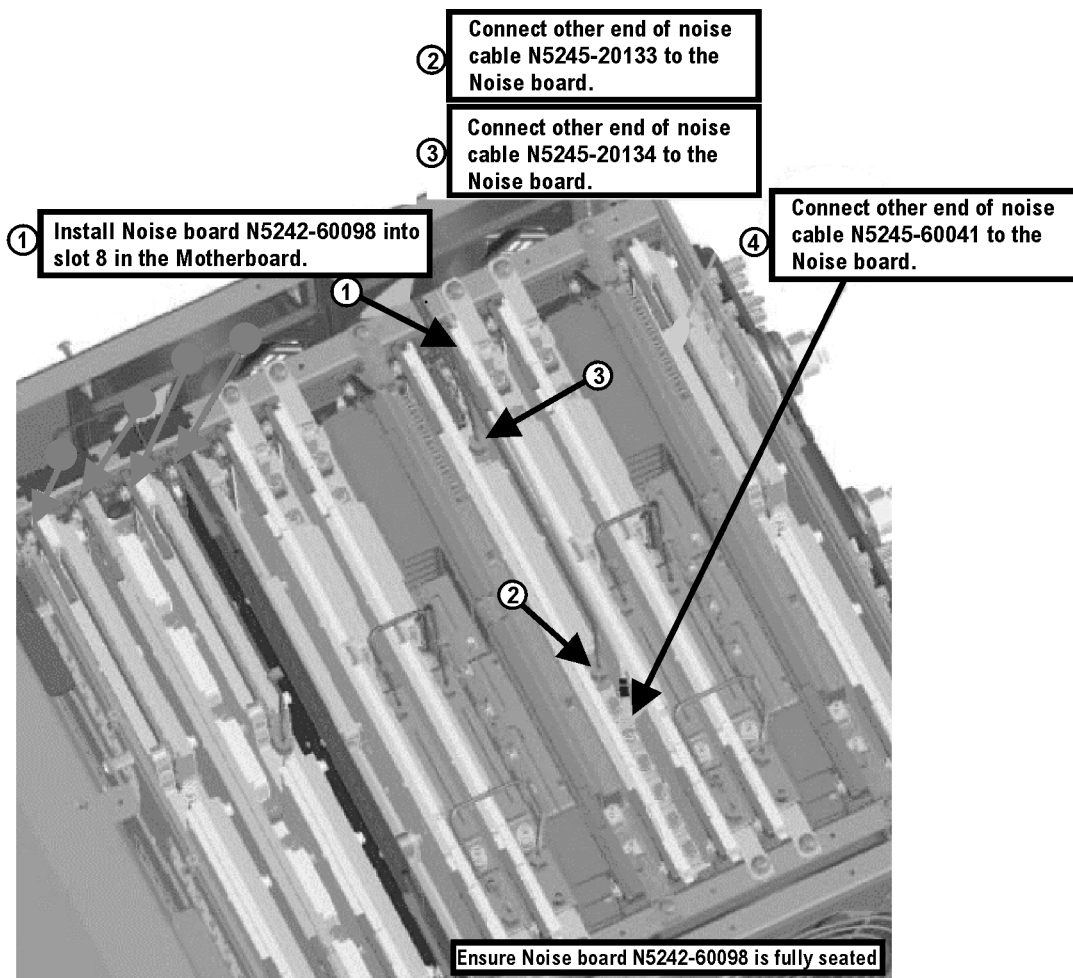

N5245\_109\_07

## Step 17. Replace the Lower Front Panel Overlay

Refer to [Figure 15 on page 26](#) for this step of the procedure. New parts are listed in [Table 1 on page 7](#).

1. From the back side of the front panel, use a blunt object in the cutouts in the lower front dress panel to push on the old overlay (item ①) and separate it from the front dress panel.
2. From the front side of the front panel, pull off the overlay completely and discard it.
3. Remove any adhesive remaining on the front panel.
4. Remove the protective backing from the new front panel overlay (item ②).
5. Loosely place the overlay in the recess on the lower front panel.
6. Placing the index finger of both hands at the middle, press the overlay firmly onto the frame while sliding your fingers in opposite directions towards an outside edge of the overlay. Repeat on all areas of the overlay.

**Figure 15 Lower Front Panel Overlay Replacement**

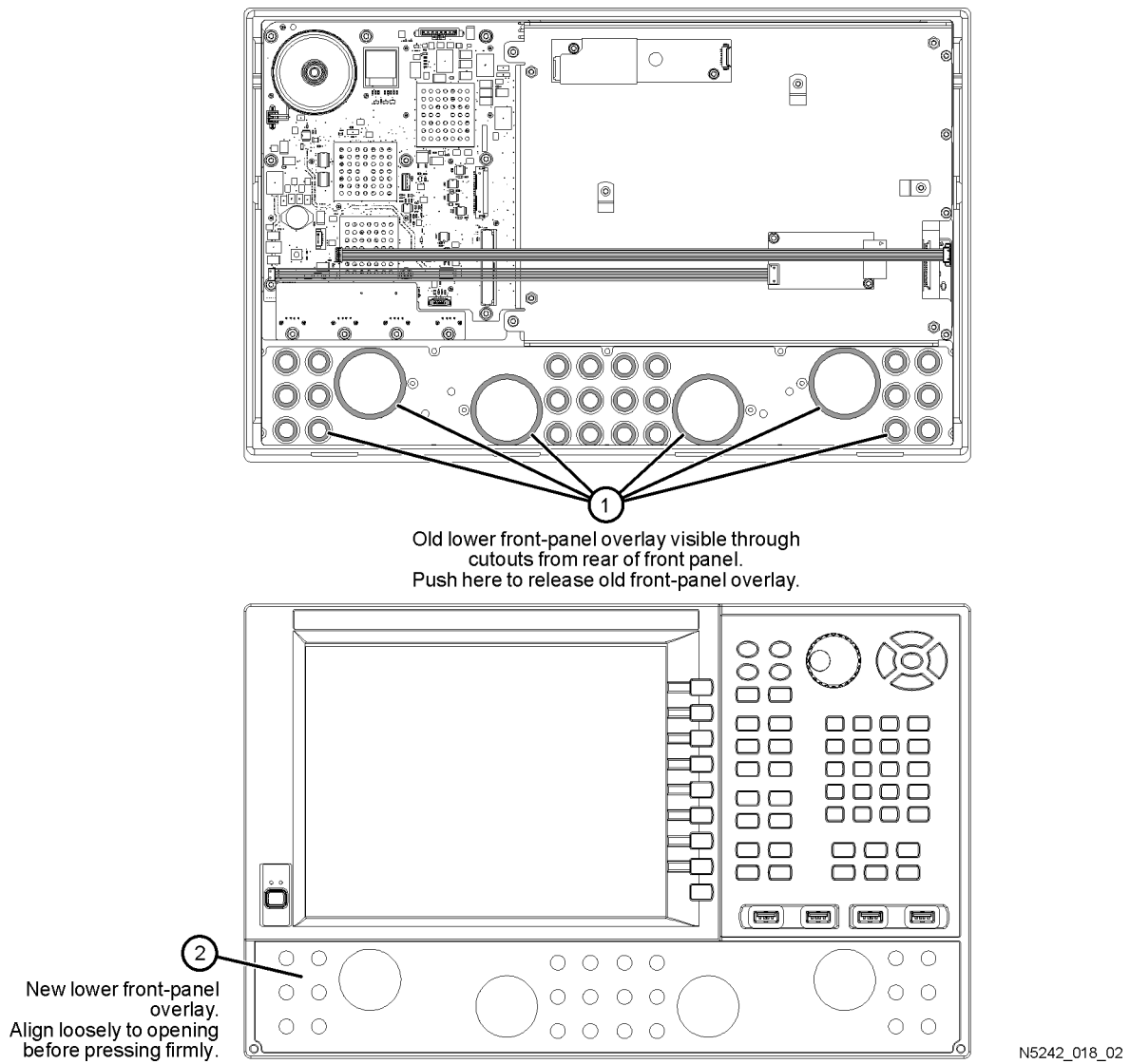

### Step 18. Reinstall the A24 IF Multiplexer Board

For instructions, click the Chapter 7 bookmark "Removing and Replacing the A24 IF Multiplexer Board" in the PDF Service Guide<sup>1</sup>.

### Step 19. Reinstall the A23 Test Set Motherboard

For instructions, click the Chapter 7 bookmark "Removing and Replacing the A23 test set motherboard" in the PDF Service Guide<sup>1</sup>.

### Step 20. Install the New Ribbon Cable on the A23 Test Set Motherboard

Ribbon cable N5245-60013 was connected earlier to the Noise Down Converter. Now connect the other end of the ribbon cable to J550 on the Test Set Motherboard.

### Step 21. Reroute the A44 and A45 Bias Tees Wire Harnesses

Follow the two instructions shown in [Figure 16](#) for this step of the procedure. The board shown in this photo may look different from the board in your PNA.

**Figure 16 Rerouting the A44 and A45 Bias Tees Wire Harnesses**

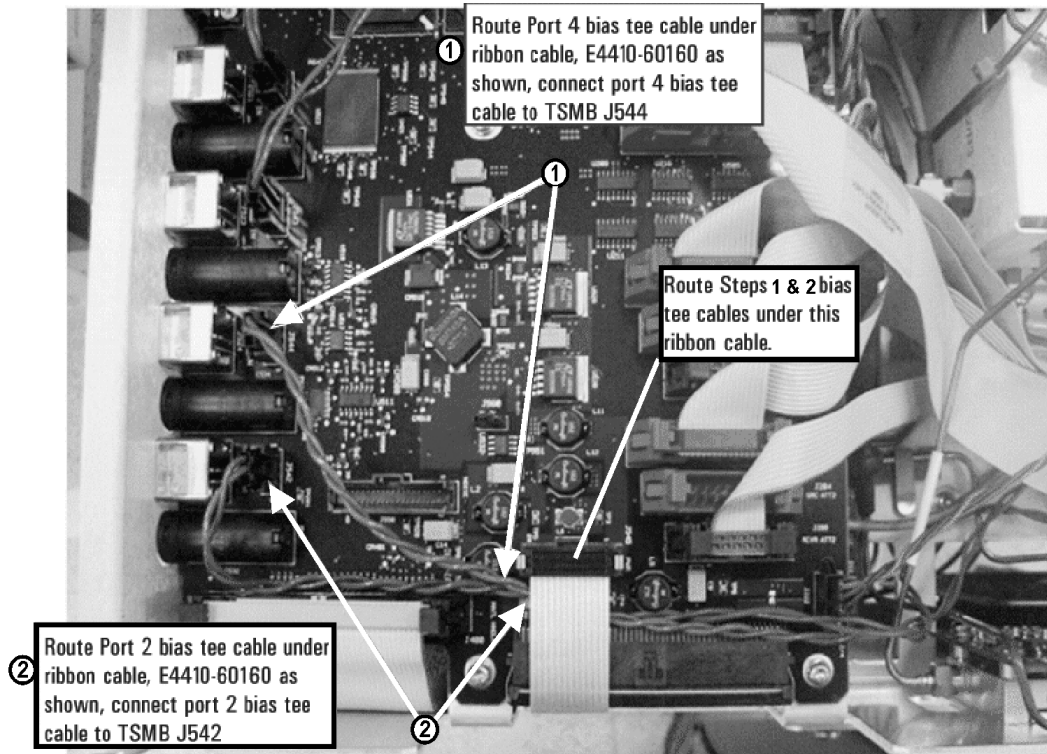

N5245\_109\_15

1. See "Downloading the Online PNA Service Guide" on page 5.

## Step 22. Reinstall Front Panel Assembly

For instructions on reinstalling the front panel assembly, click the Chapter 7 bookmark “Removing and Replacing the Front Panel Assembly” in the PDF Service Guide “[Downloading the Online PNA Service Guide](#)” on page 5.

## Step 23. Install the New Inner Cover

If not already done, discard the old inner cover. Install the new inner cover (part number N5247-00004) included with this upgrade kit. For instructions, click the Chapter 7 bookmark “Removing the Covers” in the PDF Service Guide<sup>1</sup>.

## Step 24. Reinstall the Outer Cover

For instructions, click the Chapter 7 bookmark “Removing the Covers” in the PDF Service Guide<sup>1</sup>.

## Step 25. Enable Option H29

### Procedure Requirements

- The analyzer must be powered up and operating to perform this procedure.
- The Network Analyzer program must be running.
- A keyboard must be connected to the network analyzer.

### Option Enable Procedure

NOTE: You must have a keyword to enable this option. If you have not yet obtained the necessary keyword, refer to “[Step 1. Obtain a Keyword](#)” on page 10 for instructions.

1. To start the option enable utility, press UTILITY **System**, then **Service**, then **Option Enable**. An option enable dialog box will appear.
2. Click the arrow in the **Select Desired Option** box. A list of available options will appear.
3. In the **Select Desired Option** list, click **H29 - Full Noise Measurements**.
4. Using the keyboard, enter the keyword you obtained, in the box provided. Enter this keyword *exactly* as provided.
5. Click **Enable**.
6. Click **Yes** in answer to the displayed question in the **Restart Analyzer?** box.
7. When the installation is complete, click **Exit**.

### Option Verification Procedure

Once the analyzer has restarted and the Network Analyzer program is again running:

1. On the analyzer’s **Help** menu, click **About Network Analyzer**.
2. Verify that “H29” is listed after “Options:” in the display. Click **OK**.

---

**NOTE** If Option H29 has not been enabled, perform the [“Option Enable Procedure”](#) again. If the option is still not enabled, contact Agilent Technologies. Refer to [“Getting Assistance from Agilent”](#) on page 3.

---

## **Step 26. Perform Post-Upgrade Adjustments and Calibration**

### **Adjustments**

The following adjustments must be made due to the hardware changes of the analyzer.

- Default EE adjustment - select the LO Drive-NF adjustment and initialize the values.
- Source adjustment
- Receiver adjustment
- Noise figure adjustment

These adjustments are described in the PNA Service Guide and in the PNA on-line HELP. A list of equipment required to perform these adjustments is also found in the service guide.

To view the Service Guide online, use the following steps:

1. Go to [www.agilent.com](http://www.agilent.com)
2. In the Search box, enter the model number of your analyzer, N5245A, and click **Search**.
3. Click [Technical Support](#) > [Manuals](#).
4. Click Service Manual.
5. Click the service guide title to load the PDF file.
6. When the PDF of the Service Guide is displayed, scroll through the Contents section bookmarks to locate the “Tests & Adjustments” chapter.

After the specified adjustments have been performed, the analyzer should operate and phase lock over its entire frequency range.

### **Operator’s Check**

Perform the Operator’s Check to check the basic functionality of the analyzer. For instructions, refer to the “Tests & Adjustments” chapter of the Service Guide.

If you experience difficulty with the basic functioning of the analyzer, contact Agilent. Refer to [“Contacting Agilent”](#) on page 3.

### **Calibration**

Although the analyzer functions, its performance relative to its specifications has not been verified. It is recommended that a full instrument calibration be performed using the analyzer’s internal performance test software. Refer to the analyzer’s service guide for information on this performance test software.

**Step 27. Prepare the PNA for the User**

1. If necessary, reinstall front jumper cables.
2. Install the cable guards, pushing them over the front jumper cables until the cushioning material touches the front panel of the PNA.
3. Install the dust caps on the test ports.
4. Clean the analyzer, as needed, using a damp cloth.